

Memoright Standard GTR Series

2.5” Form Factor

NAND Flash Solid State Drive

Model Code: MRS020AxxxGT*25I**

Product Specification

Version 1.0

Overview

The NSSD (NAND Flash-based Solid State Drives) of Memoright consists of semiconductor devices completely, and the storage media is NAND Flash which has high reliability and high compatibility.

As the NSSD doesn't have any mechanical part such as platter (disk), motor and suspension, it gives a good solution in a UMPC and Tablet PC for a storage device with high performance and low power consumption and small form factor.

At the same time it gives rugged feature in industrial PC with an extreme environment and an increased MTBF.

For an easy adoption, the NSSD has the same device interface and physical dimension with HDD.

Change History		
Rev.	Update	Updated
1.0	Separate GT & GTR into two datasheet	2012/2/16

INFORMATION IN THIS DOCUMENT IS PROVIDED IN RELATION TO MEMORIGHT PRODUCTS, AND IS SUBJECT TO CHANGE WITHOUT NOTICE.

NOTHING IN THIS DOCUMENT SHALL BE CONSTRUED AS GRANTING ANY LICENSE, EXPRESS OR IMPLIED, BY ESTOPPEL OR OTHERWISE, TO ANY INTELLECTUAL PROPERTY RIGHTS IN MEMORIGHT PRODUCTS OR TECHNOLOGY.

ALL INFORMATION IN THIS DOCUMENT IS PROVIDED ON AS "AS IS" BASIS WITHOUT GUARANTEE OR WARRANTY OF ANY KIND.

For updates or additional information about Memoright products, contact your nearest Memoright office.

Copyright © 2012 by Memoright Corporation. All rights reserved.

Information contained in this document, including but not limited to any instructions, descriptions and product specifications, is proprietary to Memoright Inc. and shall not be modified, used, copied, reproduced or disclosed in whole or in part, in any form or by any means, electronic or mechanical, for any purpose, without the written consent of Memoright Corporation.

Ordering information

Product Code Decoder

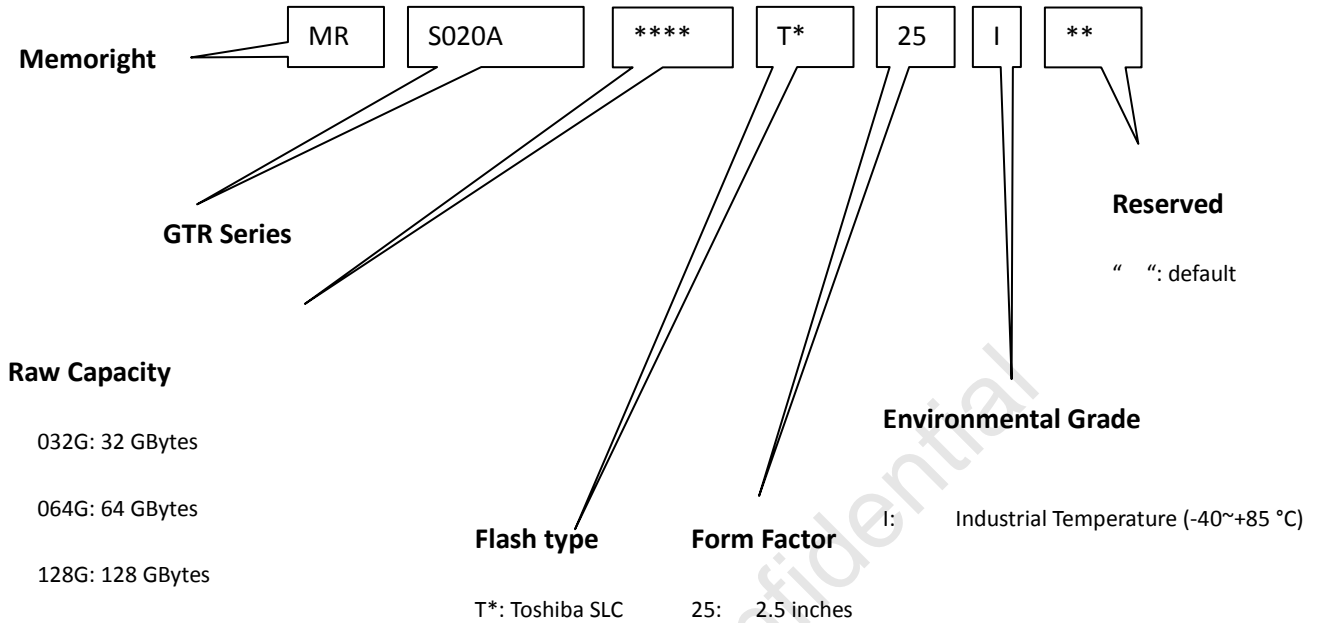

Product code

Memoright GTR Series	
Part Number	Description
MRS020A128GT025I00	128 GB, SLC, 2.5" NAND Flash SSD, Industrial Solution
MRS020A064GT925I00	64 GB, SLC, 2.5" NAND Flash SSD, Industrial Solution
MRS020A032GT825I00	32 GB, SLC, 2.5" NAND Flash SSD, Industrial Solution

For the latest ordering information, please consult Memoright's sales representatives or check on our website: <http://www.memoright.com>

Content

Overview	1	1.7.4 Humidity	7
Ordering information	3	1.7.5 Altitude	7
<i>Product code</i>	3	<i>Functional Block Diagram</i>	8
<i>DecoderContent</i>	3	<i>Physical specifications</i>	9
<i>Content</i>	4	<i>Drive Specifications</i>	10
<i>List of Tables</i>	6	1.8 Physical organization	11
<i>List of Figures</i>	6	1.9 Recording and interface technology	11
<i>General Description</i>	7	1.10 Physical characteristics	11
<i>General Description</i>	7	1.11 Access time	11
1.1 Raw capacity	7	1.12 Power specifications	11
1.2 Form Factor	7	1.12.1 Power consumption	11
1.3 Host interface	7	1.12.2 Conducted Noise	12
1.4 Performance	7	1.12.3 Voltage tolerance	12
1.5 Reliability	7	1.13 Environmental specifications	12
1.5.1 Wear Leveling	7	1.13.1 Operating temperature	12
1.5.2 Endurance	7	1.14 Reliability	13
1.5.3 ECC	7	1.15 Agency certification	13
1.5.4 Bad block management algorithm	7	1.16 Environmental protection	13
1.5.5 Mean Time between Failures	7	2 Configuring and mounting the drive	14
1.5.6 Data Retention	7	2.1 Static discharge and handling	14
1.6 Power consumption	7	<i>precautions</i>	14
1.7 Environmental	7	2.2 Drive mounting	14
1.7.1 Temperature	7	2.3 Installation considerations	14
1.7.2 Shock	7	3 SATA interface	16
1.7.3 Vibration	7	3.1 SATA interface signals and	16
		connector pins	16

Memoright GTR Series product specification

3.1.1	Signal Segment Pin-out Configuration.....	16	3.2.15	S.M.A.R.T (B0h).....	20
3.1.2	Power Segment Pin-out Configuration.....	16	3.2.16	Read Multiple (C4h).....	20
3.2	Supported ATA commands.....	18	3.2.17	Write Multiple (C5h).....	20
3.2.1	Recalibrate (10h).....	18	3.2.18	Set Multiple Mode (C6h).....	20
3.2.2	Read Sector(s) (20h).....	19	3.2.19	Read DMA (C8h).....	20
3.2.3	Read Sector(s) EXT (24h).....	19	3.2.20	Write DMA (CAh).....	20
3.2.4	Read DMA EXT(25h).....	19	3.2.21	Standby Immediate (E0h).....	20
3.2.5	Read Multiple EXT(29h).....	19	3.2.22	Idle immediate (E1h or 95h).....	20
3.2.6	Write Sector(s) (30h).....	19	3.2.23	Standby (E2h).....	21
3.2.7	Write Sector(s) EXT(34h).....	19	3.2.24	Idle (E3h).....	21
3.2.8	Write DMA EXT(35h).....	19	3.2.25	Read Buffer (E4h).....	21
3.2.9	Write Multiple EXT(39h).....	19	3.2.26	Check Power (E5h or 98h).....	21
3.2.10	Read/Verify Sector(s) (40h).....	19	3.2.27	Sleep (E6h).....	21
3.2.11	Read Verify Sector(s) EXT(42h) 19	19	3.2.28	Flush Cache (E7h).....	21
3.2.12	Seek (70h).....	19	3.2.29	Write Buffer (E8h).....	21
3.2.13	Execute Device Diagnostic (90h) 20	20	3.2.30	Flush CACHE EXT(EAh).....	21
3.2.14	Initialize Device Parameters (91h).....	20	3.2.31	Identity Device (ECh).....	21
			3.2.32	Set Features (EFh).....	25
			3.2.33	Set Features command.....	25
			Sales and technical support.....		27

List of Tables

Table 1: Specifications Summary	10
Table 2: Physical organization	11
Table 3: Recording and interface	11
Table 4: Physical characteristics	11
Table 5: Power Consumption	12
Table 6: Ambient temperature	13
Table 7: SATA Connector Signal Definitions	16
Table 8: SATA Connector Power segment Definitions	17
Table 9: Supported ATA commands	18
Table 10: Drive-specific features	22
Table 11: Set features description	26

List of Figures

Figure 1: Block diagram	8
Figure 2: Dimension	9
Figure 3: SATA Pin	16

1. General Description

Memoright GTR Series Solid State Drive consists solely of semiconductor devices, with high reliability and high compatibility SLC NAND Flash.

As GTR Series SSD doesn't have any mechanical part such as platter (disk), motor and suspension, it gives a good solution in a UMPC, Tablet PC, Server for a storage device with high performance, low power consumption and small form factor. At the same time it provides ruggedized solutions for industrial use with an extreme environment and an increased MTBF.

For an easy adoption, the GTR Series has the same device interface and physical dimension with HDD.

1.1 Raw capacity

32 GB, 64 GB, 128 GB

1.2 Form Factor

2.5" Type (100.20 x 69.85 x 9.50) mm

1.3 Host interface

PIO Mode 0 to 4
UDMA Mode 0 to 6
Serial ATA 2.0 specification

1.4 Performance

Host Interface: Max. 300 MB/S
Sustained Read transfer: up to 100 MB/s
Sustained Write transfer: up to 106 MB/s
Access time: < 0.1ms
Random IOPS Read @4Kbytes: up to 4,900
Random IOPS Write @4Kbytes: up to 230

1.5 Reliability

1.5.1 Wear Leveling

Both dynamic and static wear leveling strategy, which ensures all blocks have nearly same wear level, reducing dependence of write endurance on access pattern.

1.5.2 Endurance

5 yrs sequential write (for one full drive's capacity write per day)

1.5.3 ECC

It provides Enhanced ECC algorithm, which reduces error rate and enforces write endurance at same time. BCH-8 bit per 512K Bytes (Toshiba).

1.5.4 Bad block management algorithm

This drive has a certain number of reserved blocks. When a user data block fails, a reserved block will replace the failed block. The replacement of bad block is transparent to user.

1.5.5 Mean Time between Failures

More than 4,000,000 hours

1.5.6 Data Retention

Data retention :>10 years
Test under room temperature.

1.6 Power consumption

Input voltage: +5 VDC,
Input current : 2 A Max.(Transient)
Write: 2.55 W(Average)
Idle : 1 W(Average)
Test under room temperature @ 5V

1.7 Environmental

1.7.1 Temperature

Operating: -40°C ~ +85°C(I-Temp)

Non-Operating: -55°C ~ +95°C(I-Temp)

1.7.2 Shock

Operating: 11ms @50G, Half Sine Wave
Non-Operating: 0.5ms@1500G, Half Sine Wave

1.7.3 Vibration

Operating: 16.4G Peak, 10~2000Hz, x3 Axis

1.7.4 Humidity

5~95% (Non-condensing)

1.7.5 Altitude

-1000~80,000 ft

2.Functional Block Diagram

Figure 1: Block diagram

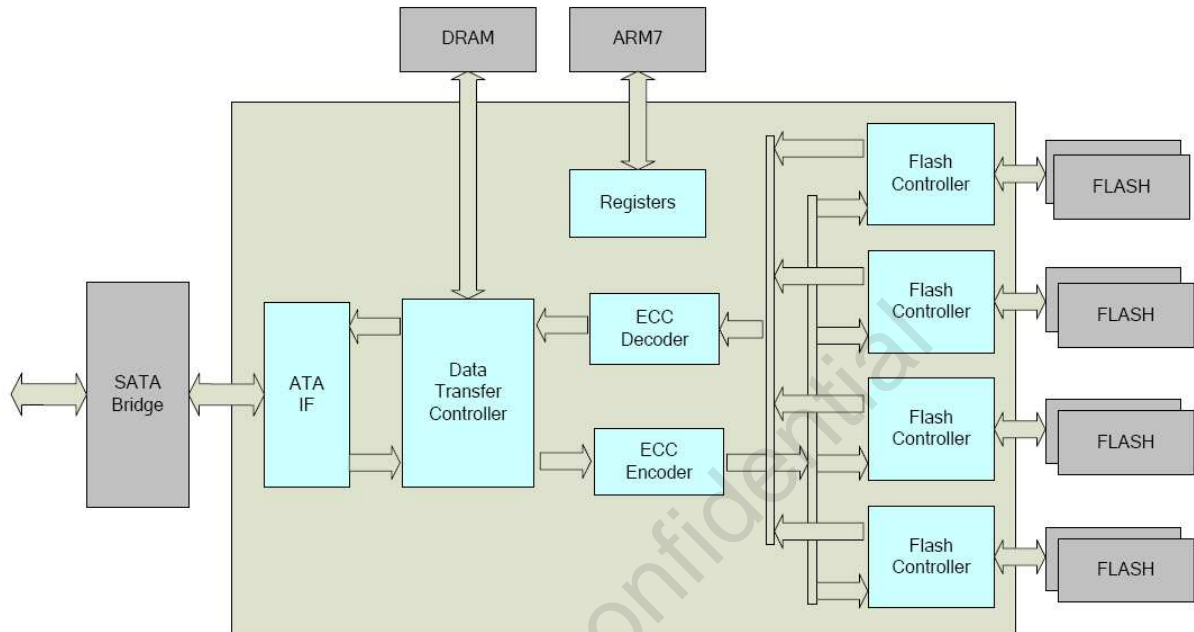

3. Physical specifications

Figure 2: Dimension

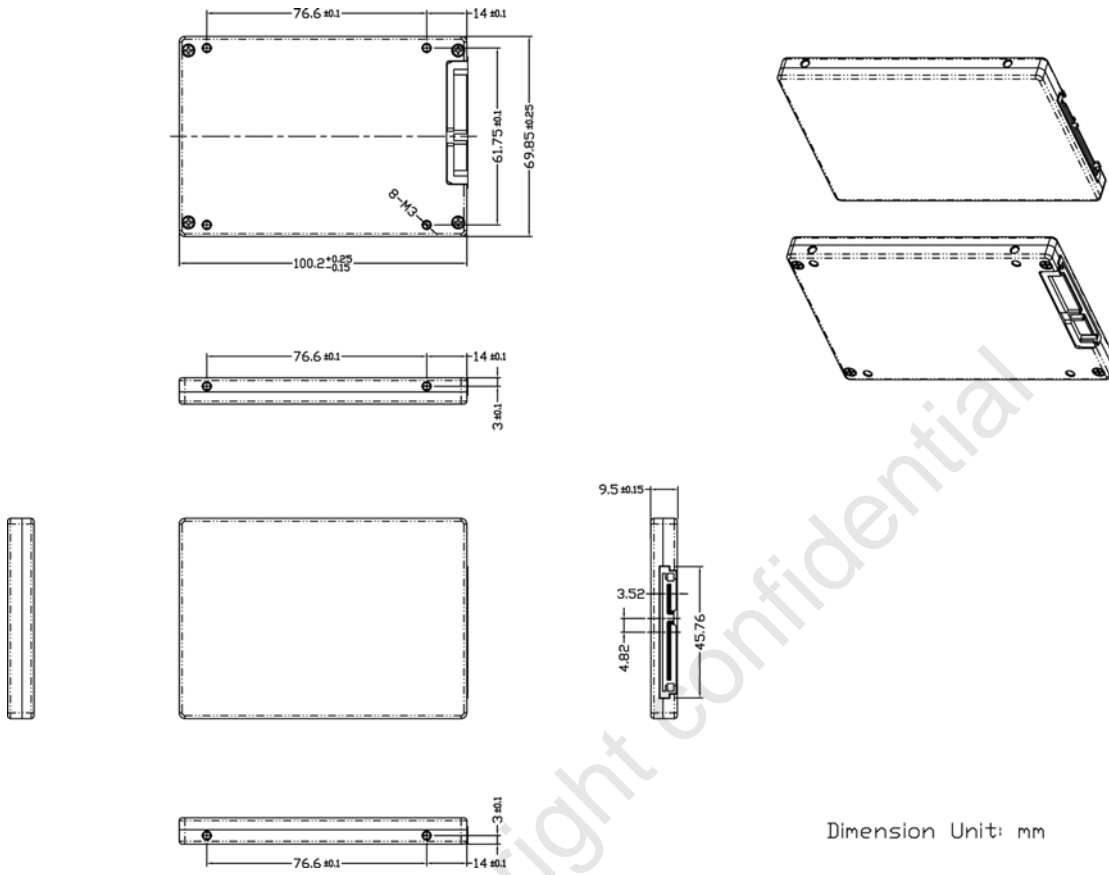

4. Drive Specifications

Unless otherwise noted, all specifications are measured under ambient conditions, at 25°C, and nominal power.

Specification Summary table

The specifications listed in the table below are for quick reference.

Table 1: Specifications Summary

Unformatted capacity	32GB	64GB	128 GB *
Max data transfer rate (read)	100 MB/s	100 MB/s	100 MB/s
Max data transfer rate (write)	106 MB/s	106 MB/s	106 MB/s
Channels	4		
Media type	Single Layer Cell (SLC) NAND Flash		
Max Random 4KB IOPS(read)	4,900	4,900	4,900
Max Random 4KBytes IOPS(write)	230	230	230
Interface	Serial ATA 2.0		
Cache buffer	64 Mbytes		
Height	9.5 ⁰ _{-0.1} mm (0.374 ⁰ _{-0.004} inches)		
width	69.85 ⁰ _{-0.1} mm (2.75 ⁰ _{-0.004} inches)		
Length	100.5 ⁰ _{-0.1} mm (3.96 ⁰ _{-0.004} inches)		
Average latency(Typical)	< 0.1 msec		
Continue write power (Typical)*	2.5watt	2.5watt	2.65watt
Idle mode power(Typical) **	1 watts	1 watts	1 watts
Operating temperature	-40°C to +85°C (I-Temp)		
Humidity (non-condensing)	5%~95% (operating)		
Shock (Operating)	50G (duration 11msec, Half Sine Wave)		
Shock (Non-Operating)	1500G (Duration 0.5msec, Half Sine Wave)		
Drive acoustics, sound power (dB)	0		
Non-recoverable read errors	< 10 ⁻¹⁶		
Mean Time Before Failure (MTBF)	> 4,000,000 hours		
Altitude	-1000~80000(Ft)		

* 1GB = 1,000,000,000 Bytes

** typical value under room temperature

4.1 Physical organization

Table 2: Physical organization

Channels
4

The number of channels means the maximum NAND flash units parallel involved in each host command execution.

4.2 Recording and interface technology

Table 3: Recording and interface

Technology	Specification
Interface	Serial ATA 2.0
Interface data transfer rate	3.0Gbps
Recording media	Single Layer Cell(SLC) NAND flash

4.3 Physical characteristics

Table 4: Physical characteristics

Height	(mm)	9.5 ⁰ _{-0.5}
Width	(mm)	69.85 ^{0.25} _{-0.25}
Length	(mm)	100.2 ^{0.25} _{-0.15}
Typical weight	(grams)	100

4.4 Access time

The time accessing to data in HDD equals to that the seek time plus the latency time, not including controller time overhead. But for SSD, the latency time is 0, and the seek time is very small. Most of the time is consumed by controller overhead.

The access time definition here is measured from the last byte of host command received by drive to the first data byte sent to host by drive in read operation.

4.5 Power specifications

The drive receives DC power (+5V) through the interface connector.

4.5.1 Power consumption

Power requirement for the drive is listed in the table. Typical power measurements are based on an

average of drive testing, under nominal conditions, using 5.0V input voltage at room temperature.

- **Read power**

The read power is measured with three 63 sectors read operations every 100msecs.

The consecutive read power is measured with consecutive 128Kbytes read operations.

- **Write power**

The write power is measured with three 63 sectors write operations every 100msecs.

The consecutive write power is measured with consecutive 128Kbytes write operations.

- **Idle mode power**

The idle power is measured with no read/wrote operation.

Table 5: Power Consumption

Power mode	Power consumption (W) @+5V, Room Temp
Consecutive write	2.5
Idle	1

4.5.2 Conducted Noise

Input noise ripple is measured at the host system power supply across an equivalent 25-ohm resistive loading on the +5 volt line.

Using 5-volt power, the drive is expected to operate with a maximum of 100 mV peak-to-peak square-wave injected noise at up to 10 MHz.

Note: Equivalent resistance is calculated by dividing the nominal voltage by the typical RMS read/write current.

4.5.3 Voltage tolerance

Voltage tolerance (including noise): 5V \pm 5%

4.6 Environmental specifications

4.6.1 Operating temperature

Ambient temperature is defined as the temperature of the environment immediately surrounding the drive. Actual drives usual temperature should not exceed 70°C within the operating ambient conditions.

Above 1,000 feet (305 meters), the maximum temperature is decreased linearly by 1°C every 1000 feet.

Table 6: Ambient temperature

Operating	-40° to 85°C (I-temp)
Non-operating	-55° to 95°C (I-temp)

4.7 Reliability

It's well known that the reliability of a chip configuration is better than a mechanical configuration. Because the mechanical configuration is affected by too many factors, it influences the reliability of HDD very much. While the chip configuration is opposite, it makes that GTR Series SSD has a nice reliability.

4.8 Agency certification

GTR Series SSD products have passed the following agency certification: CE, FCC, C-tick & UL

4.9 Environmental protection

GTR Series SSD produces almost no quantity of heat and the noise is 0 dB when it is working. At the same time, the GTR Series SSD products and the enclosed components/devices and/or assemblies are lead-free. It has no influence on environment.

5. Configuring and Mounting the Drive

This section contains the specifications and the instructions for configuring and mounting the drive.

5.1 Static discharge and handling precautions

After unpacking and before installation, the drive may be exposed to potential handling and electrostatic discharge (ESD) hazards. Observe the following standard handling and static-discharge precautions:

Caution:

- Keep the drive in the electrostatic discharge (ESD) bag until you are ready to installation to limit the drive's exposure to ESD.
- Before handling the drive, put on a grounded wrist strap, or ground yourself frequently by touching the metal chassis of a computer that is plugged into a grounded outlet. Wear a grounded wrist strap throughout the entire installation procedure.
- Handle the drive only by its edges or frame.
- The drive is fragile, and handles it with care. Do not press down on the drive top cover.
- Always rest the drive on a padded, antistatic surface until you mount it in the computer.
- Do not touch the connector pins or the printed circuit board.
- Do not remove the factory-installed labels from the drive or cover them with additional labels. Removal voids the warranty. Some factory-installed labels contain information needed to service the drive. Other labels are used to seal out dirt and contamination.

5.2 Drive mounting

You can mount the drive using four screws in the side-mounting holes or four screws in the bottom-mounting holes. See Figure 2 for drive mounting dimensions (dimensions in inches with mm in parentheses). Follow these important mounting precautions when mounting the drive:

- Allow a minimum clearance of 0.030 inches (0.76 mm) around the entire perimeter of the drive for cooling.
- Use only M3 x 6 mounting screws.
- Do not over tighten the mounting screws (maximum torque: 5.0 inch-lb).
- Four (4) threads (0.080 inches) minimum screw engagement recommended.

5.3 Installation considerations

The advantages of GTR Series SSD are obvious comparing to HDD. More and more users of computers replace the hard drive with GTR Series SSD, or planning to do so. Refer to your system's user manual for the location of the hard drive compartment and the specific instructions regarding replacement. Refer to your system manufacturer's support website for the most up-to-date information. Read and follow all instructions regarding the proper steps to be taken when replacing the system hard drive. Some mobile systems are sealed and require specialized tools to gain access to the hard drive. Special training or tools may be needed to service some mobile computers. In some cases, opening the case may void your warranty. Consult your system documentation. Memoright recommends taking your

Memoright GTR Series product specification

system to an authorized service technician to replace your hard drive.

- Unpack the drive and keep it away from any potential ESD (Electrostatic Discharge) hazard area.
- Mount the drive with 4 screws either through the two sides of the drive or at the bottom of the drive.
- Use M3 x 6mm screws which you may find in the packing box.
- Connect the 15-Pin power cable to the power connector of the drive and connect the 7-Pin signal cable to the signal connector of the drive properly.
- Power on your host and then format the SSD or initiate the SSD through the RAID card with the standard drive format procedure.
- Please install the windows XP first then Vista if coexisted systems required.

Memoright confidential

6. SATA interface

The drive uses the industry-standard Serial ATA interface that supports 16-bit data transfers. It supports programmed input/output (PIO) modes 0–4; Ultra DMA modes 0–6. The drive also supports the use of the IORDY signal to provide reliable high-speed data transfers.

For detailed information about the Serial ATA interface, refer to the draft of AT Attachment with Packet Interface Extension (ATA/ATAPI-7), NCITS T13 1410D, subsequently referred to as the Draft ATA-7 Standard.

6.1 SATA interface signals and connector pins

The connector on Memoright SATA GTR Series SSD is divided into a signal Segment and a power Segment. The following table summarizes the signals on the SATA interface connector. For a detailed description of these signals, refer to the Draft ATA-7 Standard.

6.1.1 Signal Segment Pin-out Configuration

Figure 3: SATA Pin

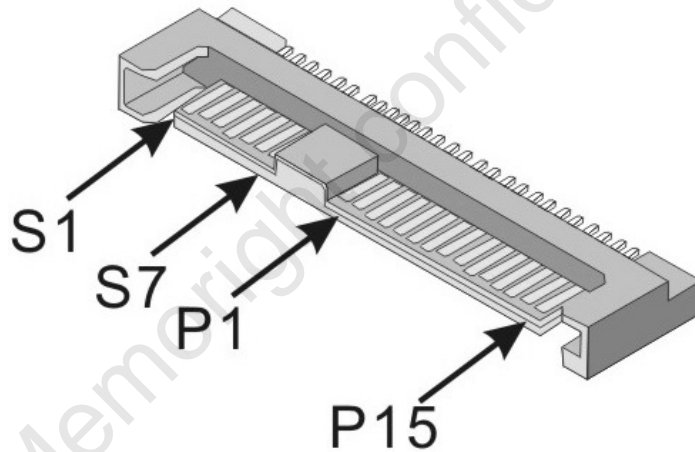

The SATA signal cable uses a protocol transmitted over a 7-pin cable. The following table lists the signal definitions of the 7-pin segment.

Table 7: SATA Connector Signal Definitions

Pin	Signal Name	Signal Definitions
S1	Ground	Second Mate
S2	R+	+Differential Receive Signal
S3	R-	-Differential Receive Signal
S4	Ground	Second Mate
S5	T-	-Differential Transmit Signal
S6	T+	+Differential Transmit Signal
S7	Ground	Second Mate

6.1.2 Power Segment Pin-out Configuration

Memoright GTR Series product specification

The SATA power connector consists of 15 pins. The following table lists the signal definitions of the 15-pin segment.

Table 8: SATA Connector Power segment Definitions

Pin	Signal Name	Signal Definitions
P1	V3.3	3.3V Power(Not used)
P2	V3.3	3.3V Power(Not used)
P3	V3.3	3.3V Power(Not used)
P4	Ground	First Mate
P5	Ground	Second Mate
P6	Ground	Second Mate
P7	V5	5V Power, pre-charge, Second Mate
P8	V5	5V Power
P9	V5	5V Power
P10	Ground	Second Mate
P11	Reserved	Reserved
P12	Ground	First Mate
P13	V12	12V Power(Not used)
P14	V12	12V Power(Not used)
P15	V12	12V Power(Not used)

6.2 Supported ATA commands

The following table lists ATA-standard commands supported by Memoright SATA GTR Series SSD. For a detailed description of the ATA commands, refer to the Draft ATA-7 Standard.

Table 9: Supported ATA commands

Command name	Code (hex)
Recalibrate	10h
Read Sectors	20h
Write Sectors	30h
Read Verify Sectors	40h
Seek	70h
Execute Device Diagnostic	90h
Initialize Device Parameters	91h
S.M.A.R.T.	B0h
Read Multiple	C4h
Write Multiple	C5h
Set Multiple Mode	C6h
Read DMA	C8h
Write DMA	CAh
Read Buffer	E4h
Flush Cache	E7h
Write Buffer	E8h
Identify Device	ECh
Set Features	EFh
Power-management	
Check Power Mode	98h, E5h
Sleep	E6h
Standby Immediate	E0h
Idle Immediate	95h, E1h
Standby	E2h
Idle	97h, E3h
48 bit addressing	
Read Sector(s) EXT	24h
Read DMA EXT	25h
Read Multiple EXT	29h
Write Sector(s) EXT	34h
Write DMA EXT	35h
Write Multiple EXT	39h
Read Verify Sector(s) EXT	42h
Flush CACHE EXT	EAh

6.2.1 Recalibrate (10h)

When this command is issued, the GTR Series SSD sets BSY and waits for that the device is initialized, and then clears BSY.

6.2.2 Read Sector(s) (20h)

This command will read from 1 to 256 sectors as specified in the Sector Count Register. A sector count of 0 (zero) requests 256 sectors. The transfer will begin at the sector specified in the Sector Number Register.

6.2.3 Read Sector(s) EXT (24h)

This command reads from 1 to 65,536 sectors as specified in the Sector Count register. A sector count of 0000h requests 65,536 sectors. The transfer shall begin at the sector specified in the LBA Low, LBA Mid, and LBA High registers.

6.2.4 Read DMA EXT(25h)

The Read DMA EXT command allows the host to read data using the DMA data transfer protocol.

6.2.5 Read Multiple EXT(29h)

This command reads the number of sectors specified in the Sector Count register.

6.2.6 Write Sector(s) (30h)

This command will write from 1 to 256 sectors as specified in the Sector Count Register. A sector count of 0 (zero) will request 256 sectors. The transfer begins at the sector specified in the Sector Number Register.

6.2.7 Write Sector(s) EXT(34h)

This command reads the number of sectors specified in the Sector Count register.

6.2.8 Write DMA EXT(35h)

The Write DMA EXT command allows the host to write data using the DMA data transfer protocol.

6.2.9 Write Multiple EXT(39h)

This command writes the number of sectors specified in the Sector Count register.

6.2.10 Read/Verify Sector(s) (40h)

This command will verify one or more sectors by transferring data from the flash media to the data buffer and verifying the ECC is correct. The command is identical to the Read Sector(s) - 20h command except that DRQ is never set and no data is transferred to the host.

6.2.11 Read Verify Sector(s) EXT(42h)

This command is identical to the Read Sector(s) EXT command, except that the device shall have read the data from the media, the DRQ bit is never set to one, and no data is transferred to the host.

6.2.12 Seek (70h)

This command will cause the device performing a range check.

6.2.13 Execute Device Diagnostic (90h)

This command performs the internal diagnostic tests implemented by the controller.

6.2.14 Initialize Device Parameters (91h)

This command will enable the host to set the number of sectors per track and the number of heads per cylinder.

6.2.15 S.M.A.R.T (B0h)

When this command is issued, the GTR Series SSD will report the SMART data to Host.

6.2.16 Read Multiple (C4h)

This command is similar to the Read Sector(s) -20h command. Interrupts are not generated on each sector, but on the transfer of a block that contains the number of sectors as defined by a Set Multiple Mode - C6h command.

6.2.17 Write Multiple (C5h)

This command is similar to the Write Sector(s) - 30h command. Interrupts are not presented on each sector, but on the transfer of a block which contains the number of sectors defined by the Set Multiple Mode - C6h command.

6.2.18 Set Multiple Mode (C6h)

This command enables the SSD to perform multiple Read and Write operations and establishes the block count for these commands.

6.2.19 Read DMA (C8h)

When this command is issued, the SSD will prepare the data, and transfer the data to host via ultra DMA protocol.

6.2.20 Write DMA (CAh)

When this command is issued, the GTR Series SSD will prepare for receiving the data transfer from host via ultra DMA protocol.

6.2.21 Standby Immediate (E0h)

This command will cause the GTR Series SSD to set BSY, enter the Standby Mode, clear BSY, and return the interrupt immediately.

6.2.22 Idle immediate (E1h or 95h)

This command will cause the drive to set BSY, enter the IDLE (READ) mode, clear BSY, and generate an interrupt.

6.2.23 Standby (E2h)

This command is similar to Standby immediate.

6.2.24 Idle (E3h)

This command is similar to Idle immediate.

6.2.25 Read Buffer (E4h)

This command enables the GTR Series SSD to transfer the buffer data in cache.

6.2.26 Check Power (E5h or 98h)

This command enables the Host to check the GTR Series SSD power mode.

6.2.27 Sleep (E6h)

This command enables the Host set GTR Series SSD into sleep mode.

6.2.28 Flush Cache (E7h)

When this command is issued, the device will flush all data in cache into GTR Series SSD disk to protect the data.

6.2.29 Write Buffer (E8h)

This command enables the GTR Series SSD to receive the buffer data from host into cache.

6.2.30 Flush CACHE EXT(EAh)

This command is used by the host to request the device to flush the write cache. If there is data in the write cache, that data shall be written to the media. The BSY bit shall remain set to one until all data has been successfully written or an error occurs.

6.2.31 Identity Device (ECh)

The Identify Device command (command code ECh) transfers information about the drive to the host following power up. The data is organized as a single 512-byte block of data, whose contents are shown in Table 7 on page 20. All reserved bits or words should be set to zero. Parameters listed with an "x" are drive-specific or vary with the state of the drive. See Section 2.0 on page 3 for default parameter settings.

The following commands contain drive-specific features that may not be included in the Draft ATA-7 Standard.

Table 10: Drive-specific features

Word	Description	Value
0	Configuration information: Bit 15: 0=ATA; 1=ATAPI Bit 7: removable media Bit 6: removable Controller Bit 0: reserved	0040h
1	Number of logical cylinders	3FFFh
2	Specific configuration	C837h
3	Number of logical heads	0010h
4	Retired	0000h
5	Retired	0000h
6	Number of logical sectors per logical track	003Fh
7-9	Retired	0000h
10-19	Serial number: 20 ASCII characters	ASCII
20	Retired	0000h
21	Retired	0000h
22	Obsolete	0000h
23-26	Firmware revision: 8ASCII characters	ASCII
27-46	Drive model number: 40 ASCII characters	ASCII
47	(Bits 7–0) Maximum sectors per interrupt on Read multiple and Write multiple (1)	8001h
48	Reserved	0000h
49	Standard Standby timer, IORDY supported and may be disabled	2F00h
50	Capabilities	4000h
51	Retired	0000h
52	Retired	0000h
53	Words 54–58, 64–70 and 88 are valid	0007h
54	Number of current logical cylinders	XXXXh
55	Number of current logical heads	XXXXh
56	Number of current logical sectors per logical track	XXXXh
57-58	Current capacity in sectors	XXXXh
59	Multiple sector setting	0101h
60-61	Total number of user address sectors(LBA mode)	XXXX XXXXh
62	Obsolete	0000h
63	Multi-word DMA transfer(Not support)	0000h
64	Flow control PIO transfer modes supported	0003h
65	Minimum Multiword DMA transfer cycle time per word	0078h
66	Manufacturer’s recommended Multiword DMA transfer cycle time per word	0078h
67	Minimum PIO transfer cycle time without flow control	0078h
68	Minimum PIO transfer cycle time with IORDY flow control	0078h
69-74	Reserved	0000h
75	No DMA QUEUED command supports	0000h
76-79	Reserved	0000h
80-81	ATA Ver support (ATA/ATAPI-7 T13 1532D revision 4a)	00FE 0021h
82	Command set supported 15 0 = Obsolete	786Bh

Memoright GTR Series product specification

	<p>14 1 = NOP Command supported 13 1 = READ BUFFER Command supported 12 1 = WRITE BUFFER Command supported 11 1 = Obsolete 10 0 = Host Protected Area Feature Set not supported 09 0 = DEVICE RESET Command not supported 08 0 = SERVICE Interrupt not supported 07 0 = RELEASE Interrupt not supported 06 1 = Look Ahead supported 05 1 = Write Cache supported 04 0 = indicate that the PACKET feature set not supported 03 1 = Power Management Feature Set supported (mandatory) 02 0 = Removable Media feature set not supported 01 1 = Security Mode Feature Set supported 00 1 = SMART Feature Set supported</p>	
83	<p>Command set supported 15 Shall be cleared to zero 14 Shall be set to one 13 0 = FLUSH CACHE EXT Command not supported 12 1 = FLUSH CACHE Command supported (mandatory) 11 0 = Device Configuration Overlay feature set not supported 10 1/0 = 48-Bit Address feature set supported /not supported 09 0 = Automatic Acoustic Management feature set not supported 08 0 = SET MAX security extension not supported 07 0 = See Address Offset Reserved Area Boot, INCITS TR27:2001 06 0 = SET FEATURES subcommand not required to spin-up after power-up 05 1 = Power-Up in Standby feature set supported 04 0 = Obsolete 03 1 = Advanced Power Management feature set supported 02 0 = CFA feature set not supported 01 0 = READ/WRITE DMA QUEUED not supported 00 0 = DOWNLOAD MICROCODE Command not supported</p>	5028h/5428h
84	<p>Command Set/Feature Supported Extension 15 Shall be cleared to zero 14 Shall be set to one 13 0 = IDLE IMMEDIATE with UNLOAD FEATURE not supported 12 0 = Reserved 11 0 = Reserved 10:9 0 = Obsolete 08 0 = 64-Bit World Wide Name not supported 07 0 = Write DMA QUEUED FUA EXT Command not supported 06 0 = Write DMA FUA EXT and WRITE MULTIPLE FUA EXT commands not supported 05 0 = General Purpose Logging feature set not supported 04 0 = Streaming feature set not supported 03 0 = Media Card Pass Through Command feature set not supported 02 0 = Media Serial Number not supported 01 1 = SMART Self-Test supported 00 1 = SMART Error-Logging supported</p>	4003h
85	<p>Command set/feature enabled 15 0 = Obsolete 14 1 = NOP Command enabled 13 1 = READ BUFFER Command enabled 12 1 = WRITE BUFFER Command enabled 11 1 = Obsolete</p>	7869h

	<p>10 0 = Host Protected Area has not been established 09 0 = DEVICE RESET Command not enabled 08 0 = SERVICE Interrupt not enabled 07 0 = RELEASE Interrupt not enabled 06 1 = Look Ahead enabled 05 1 = Write Cache enabled 04 0 = indicate that the PACKET feature is not supported. 03 1 = Power Management Feature Set enabled 02 0 = Obsolete 01 0 = Security Mode Feature Set enabled 00 1 = SMART Feature Set enabled</p>	
86	<p>Command set/feature enabled 15 0 = Reserved 14 0 = Reserved 13 0 = FLUSH CACHE EXT Command not supported 12 1 = FLUSH CACHE Command supported 11 0 = Device Configuration Overlay not supported 10 1/0 = 48-Bit Address features set supported/not supported 09 0 = Automatic Acoustic Management feature set not enabled 08 0 = SET MAX security extension not enabled by SET MAX SETPASSWORD 07 0 = Reserved 06 0 = SET FEATURES subcommand required to spin-up after power-up not enabled 05 0 = Power-Up in Standby feature set not enabled 04 0 = Obsolete 03 1 = Advanced Power Management feature set enabled 02 0 = CFA feature set not supported 01 0 = READ/WRITE DMA QUEUED Command not supported 00 0 = DOWNLOAD MICROCODE Command not supported</p>	1008h/1408h
87	<p>Command set/feature default 15 Shall be cleared to zero 14 Shall be set to one 13 1 = IDLE IMMEDIATE with UNLOAD FEATURE supported 12 0 = Reserved for Technical Report, INCITS TR-37-2004 (TLC) 11 0 = Reserved for Technical Report, INCITS TR-37-2004 (TLC) 10:9 0 = Obsolete 08 0 = 64-Bit World Wide Name not supported 07 0 = WRITE DMA QUEUED FUA EXT Command not supported 06 0 = WRITE DMA FUA EXT and WRITE MULTIPLE FUA EXT commands not supported 05 0 = General Purpose Logging feature set not supported 04 0 = Obsolete 03 0 = Media Card Pass Through Command feature set not supported 02 0 = Media Serial Number is not valid 01 1 = SMART Self-Test supported 00 1 = SMART Error-Logging supported</p>	4003h
88	Ultra DMA modes	007Fh
89	Time required for security erase unit completion	XXXXh
90	Time required for Enhanced security erase unit completion(Not support)	0000h
91	Current advanced power management value	4080h
92	Master Password Revision Code	FFFEh
93	Hardware reset result	600Bh
94-99	Reserved	0000h

100-103	Maximum user LBA for 48-bit Address feature set	XXXXh
104-126	Reserved	0000h
127	Removable Media Status Notification feature set support	0000h
128	Security Status	0001h
129-159	Vendor specific	0000h
160	CFA power mode 1(Not support)	0000h
161-175	Reserved	0000h
176-205	Current media serial number	0000h
206-254	Reserved	0000h
255	Checksum	XXXXh

6.2.32 Set Features (EFh)

This command is used by the host to establish or select certain features.

6.2.33 Set Features command

This command controls the implementation of various features that the drive supports. When the drive receives this command, it sets BSY, checks the contents of the Features register, clears BSY and generates an interrupt. If the value in the register does not represent a feature that the drive supports, the command is aborted. Power-on default has the read look-ahead and writes caching features enabled. The acceptable values for the Features register are defined as follows:

Table 11: Set features description

Value	Description
01h	Reserved
02h	Enable write cache
03h	Set transfer mode based on value in Sector Count register
04h	Obsolete
05h	Enable advanced power management
06h	Enable Power-Up In Standby feature set.
07h	Power-Up In Standby feature set device spin-up
09h	Reserved
0Ah	Reserved
10h	Reserved for Serial ATA
20h	Reserved
21h	Reserved
31h	Reserved
33h	Obsolete
42h	Reserved
43h	Reserved
44h	Obsolete
54h	Obsolete
55h	Disable read look-ahead feature
5Dh	Reserved
5Eh	Reserved
66h	Disable reverting to power-on defaults
77h	Obsolete
81h	Reserved
82h	Disable write cache
84h	Obsolete
85h	Disable advanced power management
86h	Disable Power-Up In Standby feature set
88h	Obsolete
89h	Reserved
8Ah	Reserved
90h	Reserved for Serial ATA
95h	Reserved
99h	Obsolete
9Ah	Obsolete
AAh	Enable read look-ahead feature
ABh	Obsolete
BBh	Obsolete
C2h	Reserved
CCh	Enable reverting to power-on defaults
DDh	Reserved
DEh	Reserved
E0h	Obsolete
F0-FFh	Reserved

Sales and technical support

For datasheet, documentation or customization requests, please contact Memoright SSD Design Center for further specific application and technical support

Memoright Corporation
9F, 535, Zhong Zheng Rd, XinDian Dist.,
New Taipei City, Taiwan

Tel: +886-2-2218-3789
Fax: +886-2-2218-5155
Web: <http://www.memoright.com>

Memoright confidential